

For your safety, please read the following before using.

- Do not use corrosive or flammable gas or liquid with this product.
- Please use within the rating pressure range. Do not apply pressure beyond recommended maximum withstand pressure, permanent damage to the pressure sensor may occur.
- Do not drop, hit or allow excessive shock. Even if switch body appears undamaged, internal components may be broken and can cause malfunction.
- Turn power off before connecting wiring. Wrong wiring or short circuit will damage and/or cause malfunction.
- Do not use in environment containing steam or oil vapor.
- This product is not explosion-proof rated. Do not use in atmosphere containing flammable or explosive gases.
- Wiring for pressure sensor should avoid power source line and high voltage line. If use in the same circuit, noise may cause malfunction.

A. SPECIFICATIONS

TYPE	INDAP51PNP □ (Vacuum)	INDAP52PNP □ (Positive)
Rated pressure range	0.0 ~ -101.3kPa	0.000 ~ 1.000MPa
Setting pressure range	10.0 ~ -101.3kPa	-0.100 ~ 1.000MPa
Withstand pressure	300kPa	1.5MPa
Fluid	Air, Non-corrosive/Non-flammable gas	
Set pressure resolution	kPa	0.1
	MPa	—
	kgf/cm ²	0.001
	bar	0.001
	psi	0.01
	inHg	0.1
	mmHg	1
Power supply voltage	12 to 24V DC ±10%, Ripple (P-P) 10% or less	
Current consumption	≤ 40mA (with no load)	
Switch output	PNP: open collector 2 outputs Max. load current: 125mA Max. supply voltage: 24V DC Residual voltage: ≤ 1.5V	
Repeatability(Switch output)	±0.2% F.S. ±1 digit	
	One point set mode	Adjustable (*1)
	Hysteresis mode	
Window comparator mode		
Response time	≤ 2.5ms (chattering-proof function: 25ms, 100ms, 250ms, 500ms, 1000ms and 1500ms selections)	
Output short circuit protection	Yes	
7 segment LCD display	Two color(Red/Green) main & Unit display, Orange sub-display (Sampling rate: 5 times/1sec.)	
Indicator accuracy	±2% F.S. ±1 digit (Ambient temperature: 25 ±3°C)	
Switch ON Indicator	Orange (1 & 2 Indicator) OUT1 OUT2	
Analog output (Current Output)	Output Current: 4 to 20mA ±2.5% F.S. (within rated pressure range) Linearity: ±1% F.S. Max. Load Impedance: 300Ω at power supply of 12V, 600Ω at power supply of 24V Min. Load impedance: 50Ω	
Enclosure	IP 40	
Ambient temp. range	Operation: 0 ~ 50°C, Storage: -10 ~ 60°C (No condensation or freezing)	
Ambient humidity range	Operation/Storage: 35 ~ 85% RH (No condensation)	
Withstand voltage	1000V AC in 1-min (between case and lead wire)	
Insulation resistance	50Mohm min. (at 500V DC, between case and lead wire)	
Vibration	Total amplitude 1.5mm or 10G, 10Hz-150Hz-10Hz scan for 1 minute, two hours each direction of X, Y and Z	
Shock	100m/s ² (10G), 3 times each in direction of X, Y and Z	
Temperature characteristic	±2% F.S. of detected pressure (25°C) at temp. Range of 0~50°C	
Port size	G1/8", M5	
Lead wire	Oil-resistance cable (0.15mm ²)	
Weight	Approx. 80g (with 2-meter lead wire)	

*1. Hysteresis value is adjustable within 1 ~ 8 digits for one point set mode and window comparator mode.

B. OUTPUT CIRCUIT WIRING DIAGRAMS

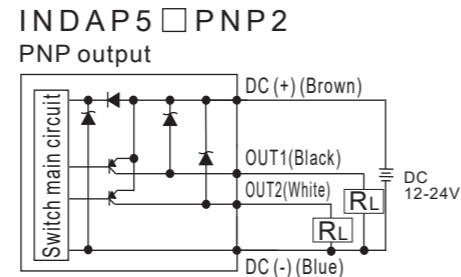
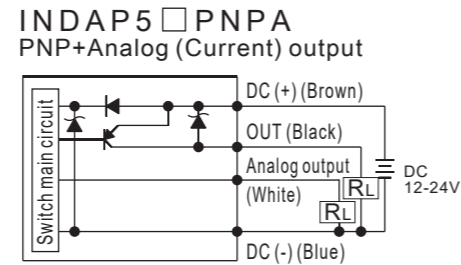

C. ORDERING INFORMATION

INDAP5 1 PNP2

Pressure Range

- 1 : Vacuum (10.0~-101.3kPa)
- 2 : Positive (-0.100~1.000MPa)

Output Specifications

PNPA : 1 PNP output + 1 Analog output(4 - 20mA)
PNP2 : 2 PNP output

Optional Parts

P42-A : Mounting bracket (BT-3+BT-4)
P40-C : Panel adapter + Front protective lid (PA-3+PA-4+FPC-2)

D. PANEL DESCRIPTION

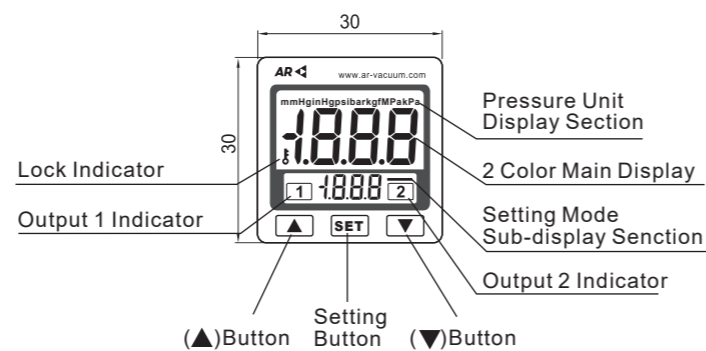

E. DIMENSIONS

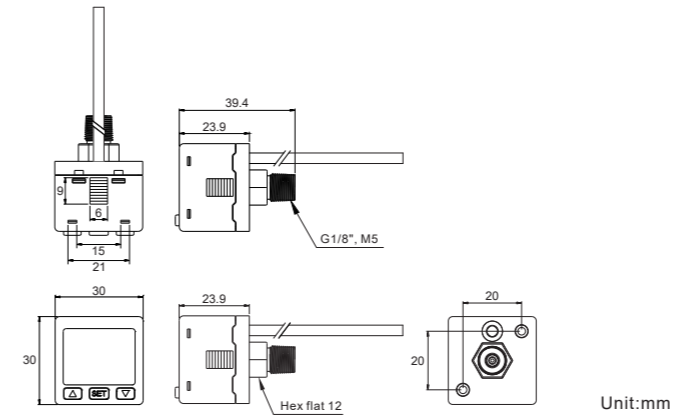

F. OPTIONAL PARTS DIMENSIONS

① Mounting bracket

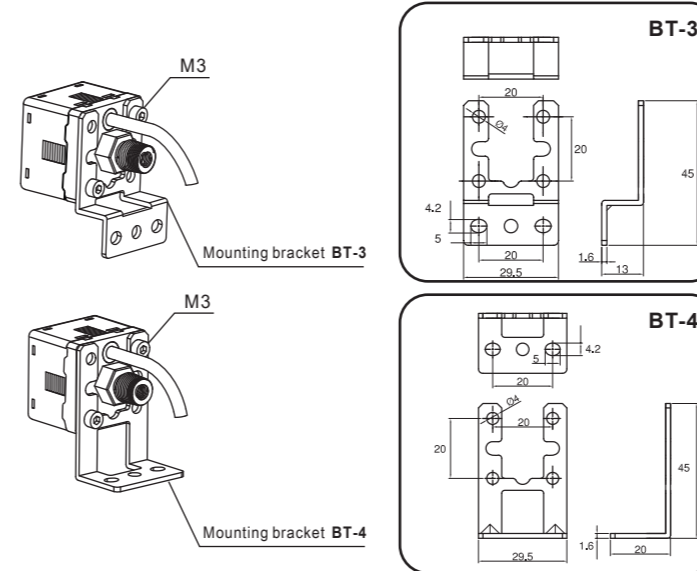

② Panel mount adapter + Front protective lid

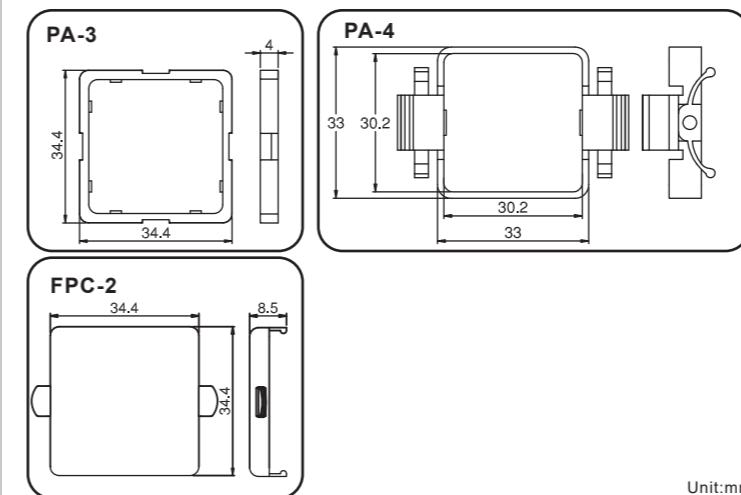
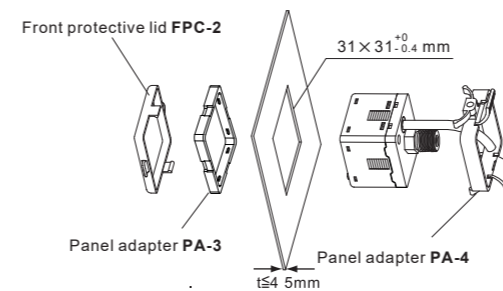

G. INITIAL SETTING MODE

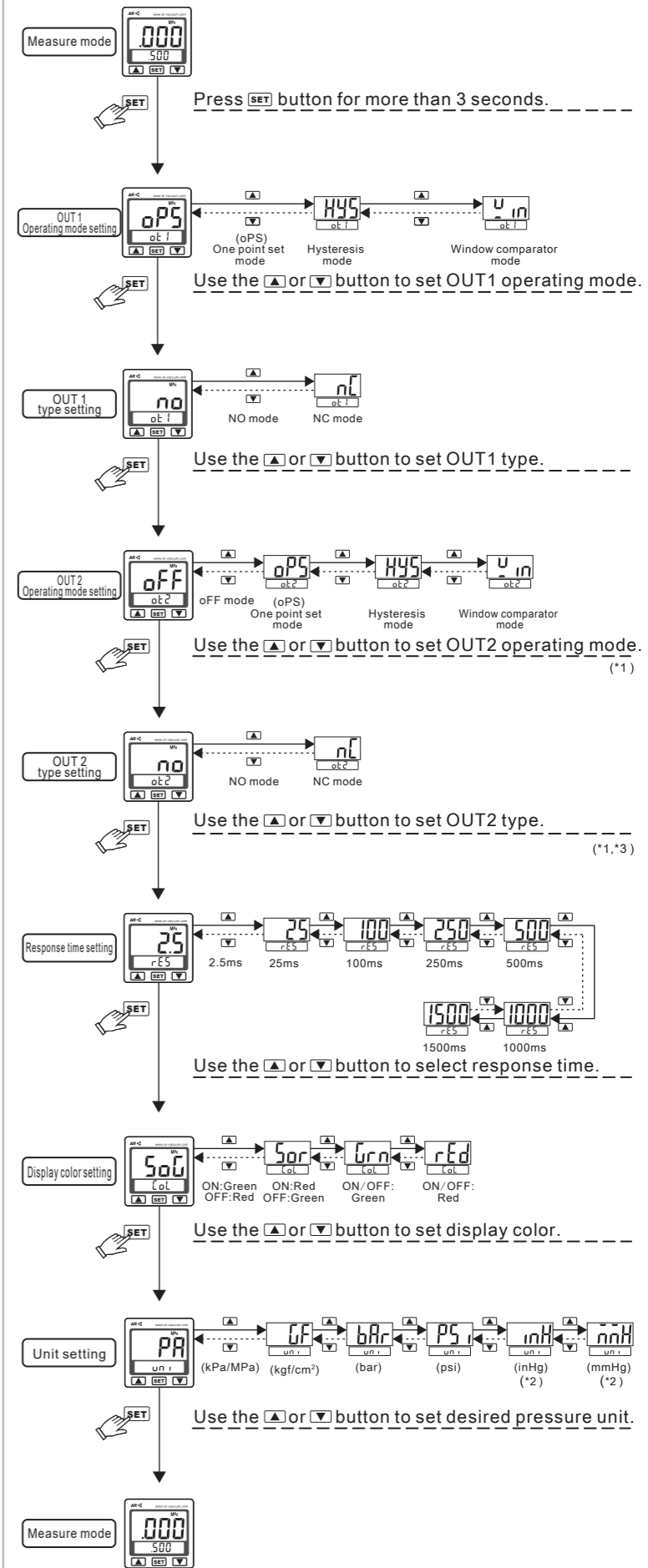

【NOTE :】

- *1. Only applicable for INDAP51PNP2, INDAP52PNP2.
- *2. This display unit is only applicable for INDAP51.
- *3. This setting mode will not display when output 2 is set to oFF.

H. ADVANCE SETTING MODE

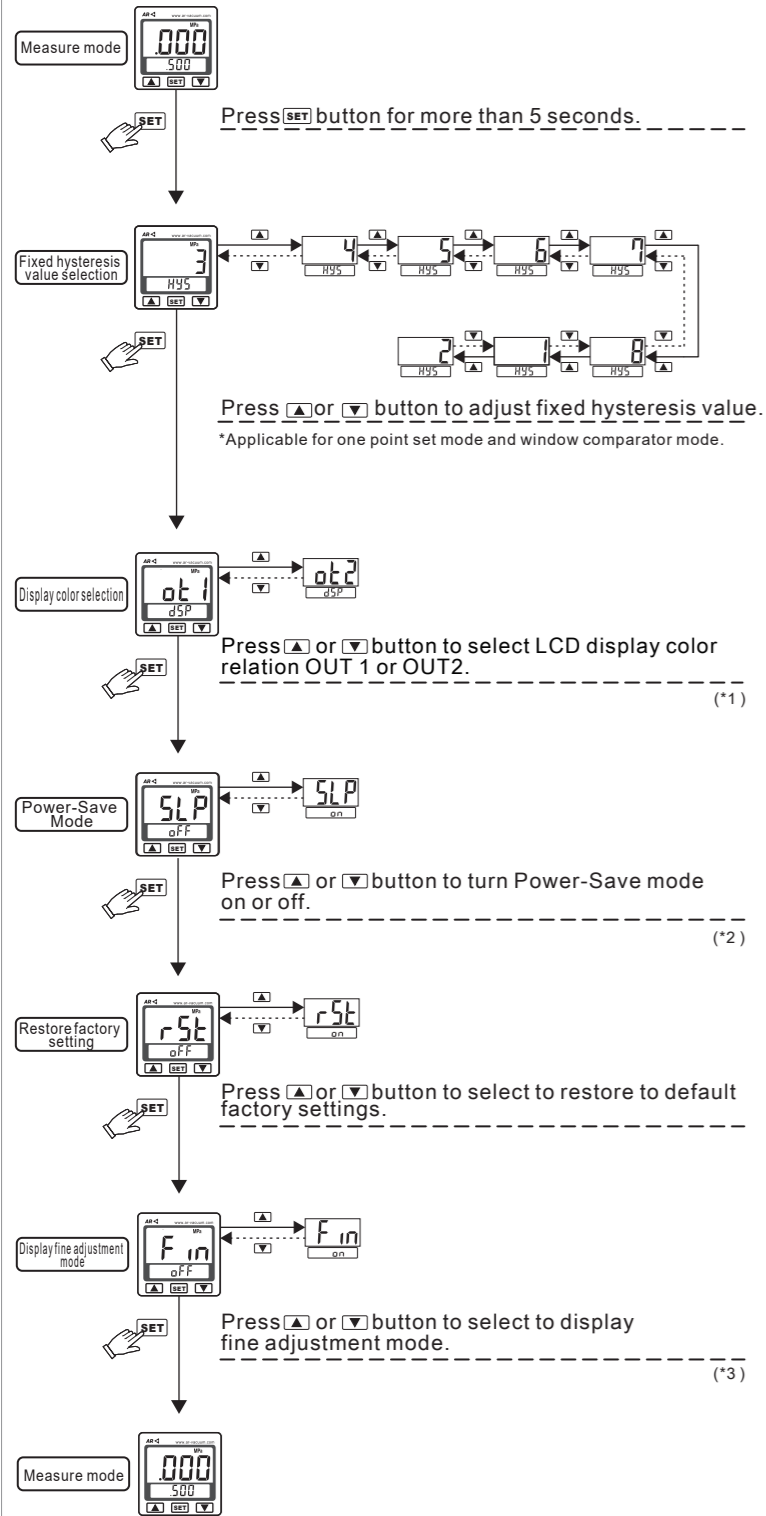

【NOTE :】
 *1. Only INDAP51PNP2 and INDAP52PNP2 have this setting selection.
 *2. When the sub-display shows "ON", Power-Save mode is activated. Please refer to Section [] for detailed explanation.
 *3. When the sub-display shows "ON", Display fine adjustment mode is activated. Please refer to Section [] for detailed explanation.

I. POWER-SAVE MODE

- During Power-Save mode, the main display will be turned off if no buttons are pressed after 30 seconds.
- During Power-Save mode, the output LCD's may not be synchronized with the output. It is normal and will not affect output operation.
- Press any button to turn-on main display temporarily.

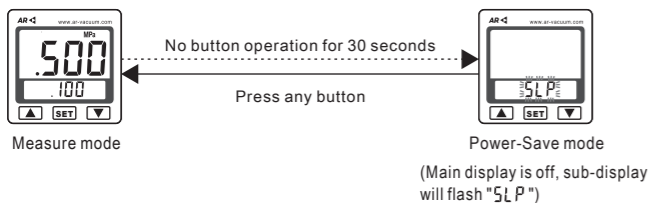

J. PRESSURE SETTING MODE

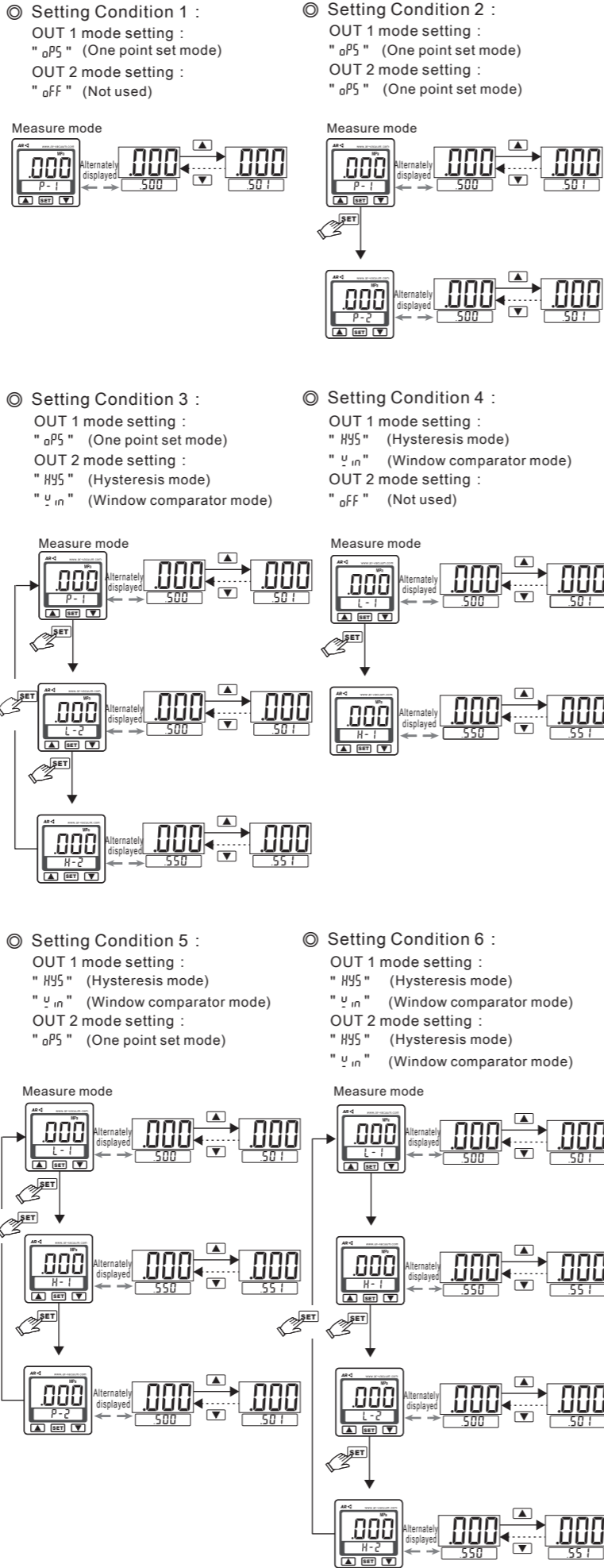

【NOTE :】
 Do not disconnect power when the sub-display and setting value is flashing alternately; otherwise the system cannot store the values.

K. OUTPUT TYPE

(1) One point set mode :

Normal open mode

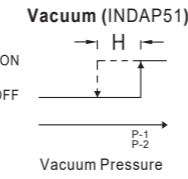
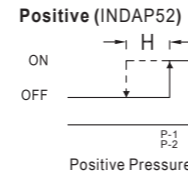

Normal close mode

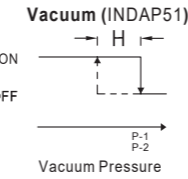
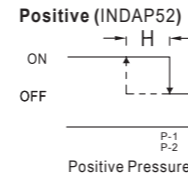

(2) Hysteresis mode :

Normal open mode

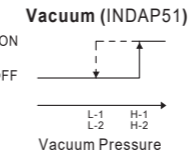
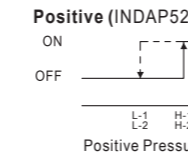

Normal close mode

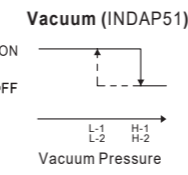
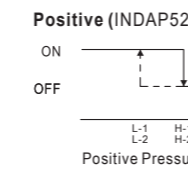

(3) Window comparator mode :

Normal open mode

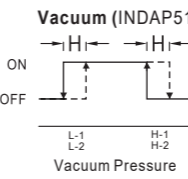
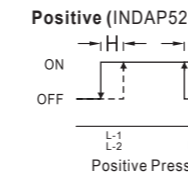

Normal close mode

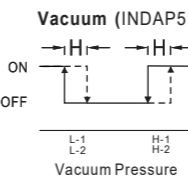
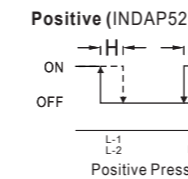

【NOTE :】

- *1 In case hysteresis is set at less than or equal to 2 digits, switch output may chatter if input pressure fluctuates near the set point.
- *2 When using window comparator mode, the difference between two set points must be greater than the fixed hysteresis, otherwise will cause the switch output to malfunction.

L. ZERO POINT SETTING

Press the Δ + ∇ button at the same time until the "00" is shown. Release the button to end zero setting.

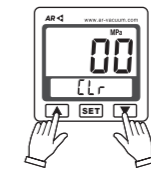

M. PEAK/BOTTOM HOLD FUNCTION

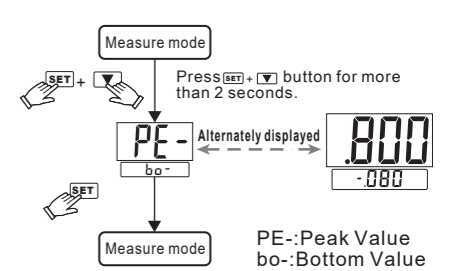

N. KEY LOCK/UNLOCK MODE

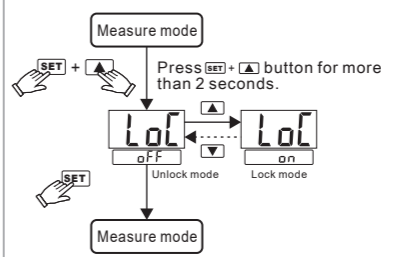

- Use key lock mode to prevent unauthorized or accidental tampering with the switch setting.
- When lock mode is selected, panel will display "L".

O. FINE ADJUSTMENT MODE

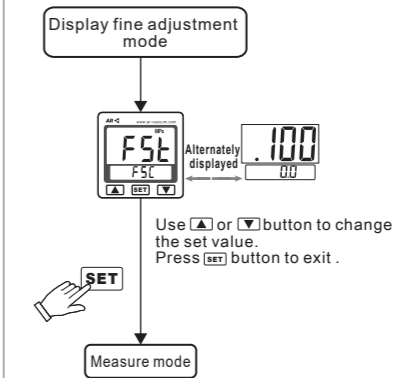

This function eliminates slight differences in the output values and allows uniformity in the numbers displayed. Displayed values of the pressure sensor can be calibrated to within $\pm 2.5\%$ R.D.

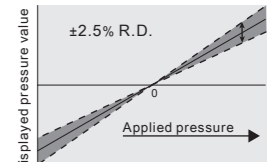

R.D. (Real Detect)

【NOTE :】
 setting resolution is $\pm 0.1\%$ R.D.

P. ERROR CODE INSTRUCTION

Error Type	Error code	Error Condition	Troubleshooting
Excess load current error	out1	Er 1 Output 1 load current is more than 125 mA	Turn power off and check the cause of overload current or lower the current load under 125 mA, then restart.
	out2	Er 2 Output 2 load current is more than 125 mA	
Residual pressure error	Er 3	During zero reset, ambient pressure is over $\pm 3\%$ F.S.	Change input pressure to ambient pressure and perform zero reset again.
Applied pressure error	HHH	Supply pressure is exceeds the upper limit of pressure setting.	Adjust the pressure within operating pressure range.
	LLL	Supply pressure is exceeds the lower limit of pressure setting.	
System error	Er 4	Internal system error	Turn power off, and then restart. If error condition remains, please return to factory for inspection.
	Er 5	Internal system error	
	Er 6	Internal data error	
	Er 7	Internal data error	

Q. PRESSURE UNIT CONVERSION TABLE

From To	Pa	kPa	MPa	kgf/cm ²	mmHg	psi	bar	inHg
1 Pa	1	0.001	0.000001	0.000010197	0.00750062	0.000145038	0.00001	0.0002953
1 kPa	1000.000	1	0.001000	0.010197	7.500616	0.145038	0.010000	0.2953
1 MPa	1000000	1000	1	10.197	7500.616	145.038	10	295.2998
1 kgf/cm ²	98066.5	98.0665	0.0980665	1	735.559	14.2233	0.980665	28.9579
1 mmHg	133.32	0.13332	0.000133	0.0013595	1	0.019336	0.0013332	0.039370
1 psi	6895	6.895	0.006895	0.07031	51.7157	1	0.06895	2.036074
1 bar	100000.0	100.0000	0.100000	1.01972	750.062	14.5038	1	29.52998
1 inHg	3386.388	3.386388	0.003386	0.034530	25.40000	0.491141	0.033863	1